

PHOTOELECTRIC LINEAR ENCODER

LK18B



Absolute Encoder



Analog output signals



Fanuc interface



BiSS interface



SSI interface



Photoelectric absolute linear encoder LK18B has measuring length of up to 3 240 mm depending on customer demand, uses SSI, BiSS or FANUC® α-ai serial interface and produces up to ±5 μm accuracy. The encoder can have an additional 1Vpp (20 μm) incremental output.

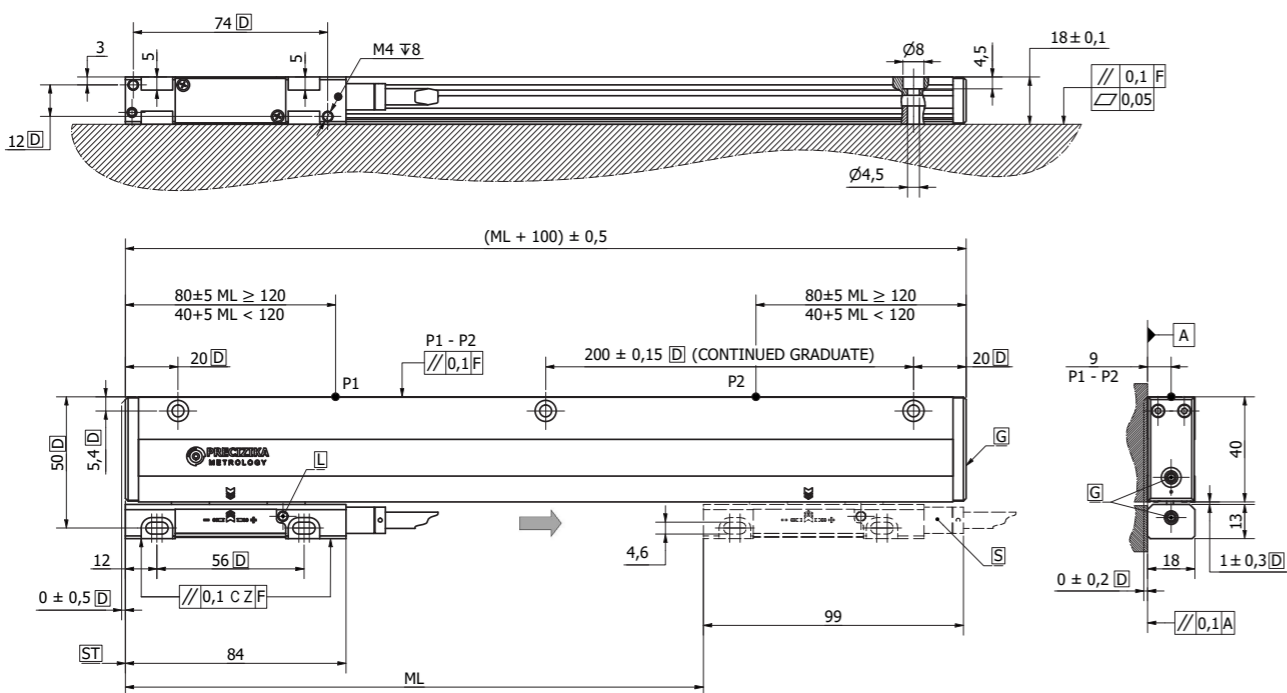

- F = Machine guideway/axis datum
- P = Gauging points for alignment
- ML = Measuring length
- D = Required mounting dimensions
- G = Compressed air inlet
- L = LED illumination
- S = Cable outlet
- ST = Beginning of measuring length ML (=20mm)
- ➔ = Direction of motion for ascending position values

MECHANICAL DATA

Measuring lengths (ML), mm	70, 120, 170, 220, 270, 320, 370, 420, 470, 520, 570, 620, 720, 770, 820, 920, 1020, 1140, 1240, 1340, 1440, 1540, 1640, 1740, 1840, 2040, 2140, 2240, 2340, 2440, 2540, 2640, 2740, 2840, 2940, 3040, 3140, 3240. (other intermediate lengths on request)	Protection (EN 60529) -without compressed air -with compressed air	IP53 IP64
Accuracy grades to any metre within the ML (at 20°C)	± 5 μm	Operating temperature	0...+50°C
Max. traversing speed:	2 m/s	Storage temperature	-20...+70°C
Max. acceleration	30 m/s²	Permissible humidity (non condensed)	20...80 %
Required moving force	≤ 5 N	Permissible vibration (55...2000 Hz)	≤ 100 m/s²
		Permissible shock (11 ms)	≤ 150 m/s²
		Weight	0.4 kg +0.8 kg/m

ELECTRICAL DATA

Version ¹⁾	SSI	BiSS-C	FANUC® α-ai
Power supply	+5 V ± 5%	+5 V ± 5%	+5 V ± 5%
Current consumption	max 250 mA	max 250 mA	max 250 mA
Measuring step ¹⁾	0.1 / 0.05 μm	0.1 / 0.05 μm	1 / 0.1 μm
Clock frequency	0.1...2 MHz	0.5...10 MHz	-
Incremental signals ¹⁾	1 Vpp (20 μm)	optional	-
Cutoff frequency -3 dB	≤ 150 kHz	≤ 150 kHz	-
Maximum cable length ²⁾	25 m	50 m	25 m

- 1) select when ordering.
 - 2) for other lengths, please contact the manufacturer.
- Note: If cable extension is used the power supply conductor section should not be smaller than 0.5 mm².

ACCESSORIES

CONNECTORS FOR CABLE	B12	C9	C12	D9	D15	F20	F20.1
	12-pin round connector	9-pin round connector	12-pin round connector	9-pin flat connector	15-pin flat connector	20-pin half pitch interface connector	20-pin half pitch 90 DEG interface connector

ORDER FORM

LK18B - X1 - X2 - X3 - X4 - X5/X6

Resolution (X1):	Measuring length (X2):	Output signals (X3):	Incremental signals (X4):	Cable length (X5):	Connector type (X6):
F005 - 0.05 μm (only for SSI / BiSS interface) F01 - 0.1 μm F10 - 1.0 μm (only for Fanuc interface)	0070 - 70 mm 0520 - 520 mm ... 3240 - 3240 mm	S1 - SSI binary S2 - SSI binary+error+warning S3 - SSI Gray B1 - BiSS binary F1 - Fanuc binary α F2 - Fanuc binary αi	W - without incremental signals V - 1Vpp (only for SSI / BiSS interface)	01 - 1m 02 - 2m 03 - 3m ...	W - without connector B12 - round, 12 pins C12 - round, 12 pins C9 - round, 9 pins D9 - flat, 9 pins D15 - flat, 15 pins F20 - half pitch, 20 pins F20.1 - half pitch, 20 pins, 90 DEG

ORDER EXAMPLE: 1) LK18B-F01-0070-S1-W-01/W